



BioHarmonex[®]

PULSED MAGNETIC FIELD EMITTER

Product Information & User's Guide

Software updates may cause changes to some features.

An updated user guide can be downloaded from the producer's website (www.bio-harmonex.com).



TABLE OF CONTENTS

BIOHARMONEX® BH4 TECHNICAL DATA.....	4
THIS PACKAGE CONTAINS	4
SAFETY AND USAGE INFORMATION	5
SAFETY WARNINGS.....	5
PROPER HANDLING, AND CARE.....	6
BATTERIES AND ACCESSORIES.....	7
AFTER-SALE SERVICING	8
WHAT IS THE BIOHARMONEX®?	10
WHAT IS IT FOR?.....	10
HOW DOES THE BIOHARMONEX® WORK?	10
PROGRAMS IN THE BIOHARMONEX®.....	10
DIETARY SUPPLEMENTS SUGGESTION.....	10
INTRODUCING BH4.0 BIOHARMONEX®	12
INSTALLING THE BATTERY	13
CHARGING THE BATTERY	13
TOUCHSCREEN.....	14
ON / OFF	14
RESET	15
OVERVIEW OF OPERATION.....	15
MODES.....	15
ACTIVE MODE.....	15
PROGRAM MODE	15
STAND-BY MODE	16
AUTO MODE.....	16
OFF MODE	16
THE MENU SYSTEM.....	17
MAIN MENU.....	17
PROGRAM GROUP MENU.....	18



STARTING A PROGRAM	18
PROGRAM RUN	20
PROGRAM WITH SOUND	21
PROGRAM WITH LIGHT EFFECT	21
TERMINATING A RUNNING PROGRAM	21
SETTINGS MENU	22
ALARM	22
ACTIVATING PROGRAMS.....	23
USB DATA TRANSFER	23
LANGUAGE	25
DATE/TIME.....	25
SET TIME	26
SET DATE	26
ABOUT	27
PROGRAMMING (MYBIO PROGRAMS)	27
NEW PROGRAM.....	28
PROGRAM MODIFY / DELETE	30
AUTO MODE	30
ORGAN CLOCK INFO	32
STARTING A PROGRAM IN THE ORGAN CLOCK.....	32
FAVORITES	33
MYBIO INFO.....	34
ACCESSORIES.....	34
BUILT-IN HELP	34
LIMITED WARRANTY	34
WARRANTY CONDITIONS	35
TROUBLESHOOTING	37



BIOHARMONEX® BH4 TECHNICAL DATA

Display type	LCD touchscreen 3.5" (480x320pixels), TFT
Description	Pulsed electromagnetic field emitter
Pulse frequency	1 Hz to 600 kHz
Output signal	Pulsed magnetic field, Pulse shape: sinus, Average magnetic field strength measured at the top of case is maximum 25 μ T.
USB Connector	MicroUSB 2.0
Audio Connector	3,5mm audio stereo jack connector
Power supply	1240mAh Li-ion battery
Charging power adapter	primary 100 to 240V AC, 50/60 Hz, 0.15A, secondary 5V, 1A
Charging time	app. 3 hours
Size	141 x 78 x 25 mm
Case material	PC-ABS/ABS plastic
Weight	140g including battery
Operating temperature	+0°C - +45°C
Humidity	Max. 90%

THIS PACKAGE CONTAINS

- Bioharmonex® device
- charger
- USB cable
- Product information and User Guide
- ***Sold separately: rubber case with neckstrap, earphones.***



SAFETY AND USAGE INFORMATION

Please read these instructions carefully. Failure to follow any, or all of these instructions may nullify the product warranty, and/or lead to damage, or technical failure of the BioHarmonex®.

SAFETY WARNINGS



The device is equipped with a special touch screen, which is fragile! Do not shake or strike the unit. Applying excessive pressure to the device or the display may cause damage and nullify the warranty!



Only the battery and charger included with the device match the charging specifications. Don't use any other charger or accessory. Damage resulting from the use of non-compatible accessories is not covered by the product warranty.



Keep the product away from liquids or high humidity. Moisture may damage the circuitry of the device, which may not be covered by the warranty. Do not use in rain or wet conditions.



Do not disassemble the device. Malfunction caused by disassembling the device is not covered by the warranty!



Use the device only between 0°C and +45°C. Do not expose the device to higher or lower temperatures, as this may shorten the life of the appliance and damage the battery.

Always observe the following precautions when using the device. This can help reduce risk of fire, electric shock, burns and other injuries.

CAUTION:

- Caution: Do not use this product in the rain or near water to prevent electric shock.
- Unplug the AC adapter from the device before performing maintenance.
- Keep the device away from heat sources and avoid contact with direct sunlight.
- Store and use the USB cable, only where it can't be stepped on or damaged. Pay particular attention to the cable connector.
- Keep your device and all accessories out of the reach of small children or animals. Small parts may cause choking or serious injury if swallowed.
- This device functions with a lithium battery, which may burst or cause burns if not used properly. To avoid problems, never disassemble the battery.



- Do not expose the battery or the BioHarmonex® device to any heat source, such as microwave ovens, stoves, heaters or radiators. Battery may explode when overheated.
- Do not crush or puncture the battery. External pressure can cause a short circuit and overheating!
- Device can be disassembled and repaired only by authorized dealer. Do not let unauthorized persons repair the device.
- To avoid damage to the display, do not place heavy objects on the device.
- In case of lightning or thunderstorms, it is not advisable to use the device outdoors.
- Do not use the device for any purpose other than proper use as outlined in the BioHarmonex® User's Guide!
- For questions, contact your dealer.

The BioHarmonex® is an electronic device. As such, do not use your device at refueling points (service stations) or near fuels or chemicals. Turn off your device whenever directed by warning signs or instructions. Your device could cause explosions or fire in and around fuel or chemical storage. Do not store or carry flammable liquids, gases or explosive materials in the same compartment as the device, its parts or accessories.

PROPER HANDLING, AND CARE

Use the device only as described in this BioHarmonex® User's Guide. Do not disassemble your device.

Allowing unqualified personnel to service your device may result in damage to your device and will void your warranty.

The device is not waterproof, or water resistant. It should be kept dry at all times and stored in a dry location. Liquids can cause serious damage to the inside of the device. Water damage to your device can void your manufacturer's warranty.

Keep the device away from extremes of cold or heat. Extreme cold may affect the seals on the plastic outer casing, which in turn, may result in moisture condensation inside the device. Do not put the device near any heat source, such as a stove, fireplace, campfire, heater, or heating outlet, as exposure to heat may affect the plastic outer casing, the casing seals, the internal circuit cards, or the internal connections. Do not store in direct sunlight.



Do not use, or store the device in a dirty or dusty place, as prolonged exposure to particles may damage the seals on the plastic casing, increasing the risk of circuit faults inside the device.

Do not hit, shake or drop the device. The device is designed to withstand a degree of handling during normal use but rough handling increases the risk of damage to the plastic outer casing, the casing seals, the display, the internal circuit cards, or the internal connections.

Do not use chemicals, solvents, strong detergents, or excessive moisture for cleaning the device. Wipe gently with a slightly damp, soft cloth.

BATTERIES AND ACCESSORIES

Power to operate the BioHarmonex® comes from a rechargeable Li-ion battery.

- The battery may be charged and discharged several hundred times, but like any battery, the power storage capacity will deteriorate with usage over time. When the power lifespan after recharging becomes very short, have the battery replaced at an authorized dealer.
- Protect batteries and chargers from damage.
- Use only batteries and chargers designed for your device. Incompatible batteries and chargers can cause serious injuries or damage to your device and can void your manufacturer's warranty.
- Never dispose of battery or devices in a fire. Follow all local regulations when disposing of used batteries or devices.
- To ensure the maximum lifespan of the battery and the charger, do not charge the device for longer than necessary, as overcharging may shorten battery lifespan.
- If the device is not used for an extended period of time, the battery may lose power and may need recharging.
- Unplug the charger from the power source when not in use. Use the battery only as intended.
- Avoid exposing battery to very cold or very hot temperatures (below 0°C/32°F or above 45°C/113°F). Extreme temperatures can reduce its charging capacity and lifespan.
- Never use a damaged charger or battery.
- There is a risk of explosion if a battery is replaced by an incorrect type.
- Dispose of used battery according to the instructions.
- Use only the accessories recommended by CaliVita® International, or its authorized service partners. Do not connect other than CaliVita® International approved accessories or devices to the BioHarmonex® outlets.



AFTER-SALE SERVICING

Only service partners authorized by CaliVita® International may perform initial activation and servicing of BioHarmonex®.

LOCATIONS RESTRICTED FOR USE

Do not turn the BioHarmonex® on, or use the device in any location where use of such a device may be restricted, or prohibited. The device may cause transmission interference during air travel, and should be switched off at all times while you are on an airplane.

IMPORTANT NOTICE

This device is not intended to treat, cure or prevent any disease. CaliVita® International only sells, and distributes this device on the basis that any, and all purchasers, and/or users of the device, have read, understood, and accepted the contents of this document in its entirety, prior to use of the device. CaliVita® International offers no specific, or implied guarantee whatsoever about the accuracy, or accountability of the information presented in this document, and is not responsible for errors and/or omissions. No regulatory body in any jurisdiction has reviewed or approved of the information presented in this publication.

CaliVita® International is not responsible for loss, or damage to the device, for reasons beyond its direct control. CaliVita® International is not responsible for damage to the device that may result from not following the instructions in this booklet. Damage to the device caused by failure to follow the instructions in this booklet, may nullify the product warranty. This document, or any part of its contents, may not be copied, or reproduced in any form, or distributed in any form, without the expressed written consent of CaliVita® International.



BH4 BioHarmonex[®] by Calivita[®] Electronics

Product Information



WHAT IS THE BIOHARMONEX®?

An electronic device that emits a very low intensity, pulsed electromagnetic field.

WHAT IS IT FOR?

According to those accepting the principles of bio-resonance, each living cell of the human body maintains its own electromagnetic field. This electromagnetic field is one method of communication between the cells in order to initiate and control the various physiological processes in our metabolism. BioHarmonex® generates an external electromagnetic field, which can support the natural processes of the body by “addressing” the natural electromagnetic field produced by certain tissues of the body.

HOW DOES THE BIOHARMONEX® WORK?

It uses the power from internal battery to emit a low frequency (1 Hz to 600 KHz) electromagnetic field. The particular pattern of the electromagnetic emission varies according to the program which is being used.

As the signals emitted by the BioHarmonex® are very low intensity, it is completely safe to use for all age groups and health levels, although if you have an implanted pacemaker or other kind of electronic device you should consult a qualified physician before using it. In case of mental disability the device can only be used under supervision! The signals cannot be felt but are effective in stimulating resonance at the cellular level as long as the subject is within 0.5 meters of the device while a program is running.

It is advisable to place the device down on the touch screen, as the wave generator coils located on top of the case.

PROGRAMS IN THE BIOHARMONEX®

Every program lasts approximately 25-45 minutes and creates resonance from the device within 0,5 meter. Most programs may be used several times per day.

For more information on the programs of the BioHarmonex® please visit our web-page (www.bio-harmonex.com).

The device is also suitable in addition to the existing programs to run another, new program purchased in our webshop.

DIETARY SUPPLEMENTS SUGGESTION

For any program, you can find our recommendation for dietary supplements to complement the program at www.calivita.com.

PLEASE NOTE:

Some of the recommended products are available only in the CaliVita® International Global Network. You may be unable to purchase them locally.

Consult with your doctor before taking supplements and using BioHarmonex® in combination.



BH4 BioHarmonex[®] by Calivita[®] Electronics

User's Guide



INTRODUCING BH4.0 BIOHARMONEX®

FRONT VIEW

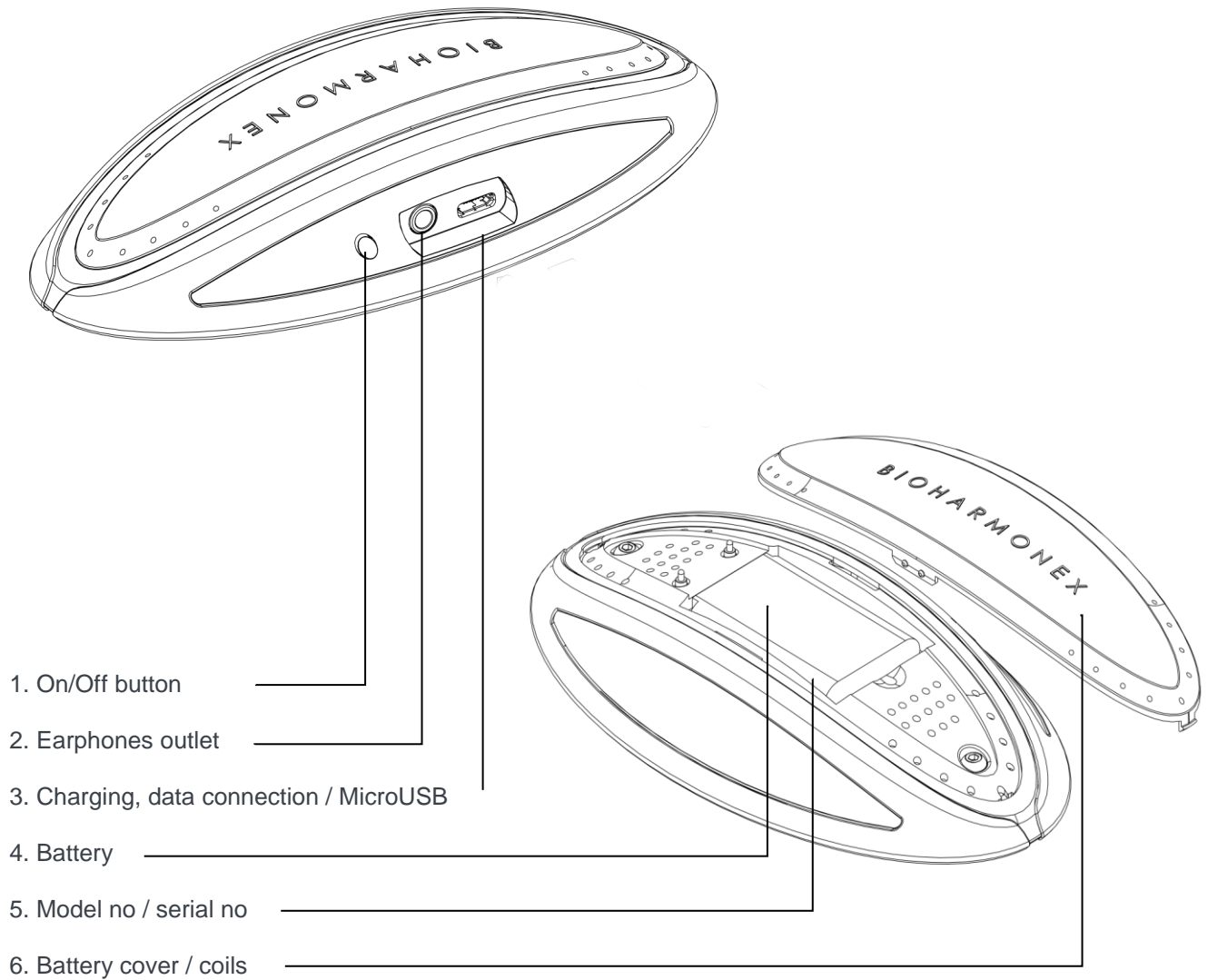

- 1. On/Off button
- 2. Earphones outlet
- 3. Charging, data connection / MicroUSB
- 4. Battery
- 5. Model no / serial no
- 6. Battery cover / coils



TOP VIEW

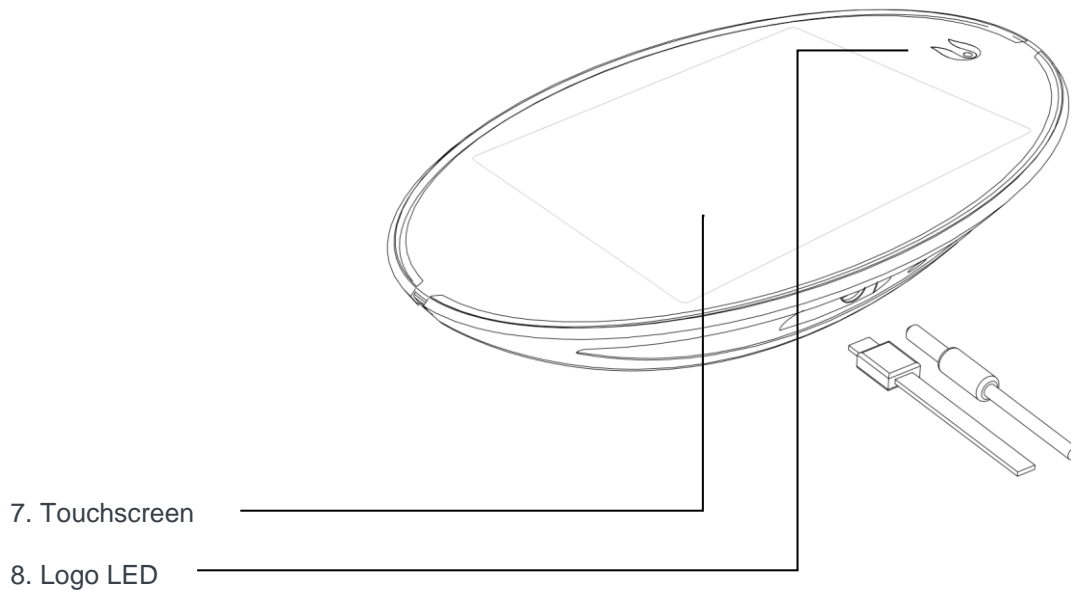

7. Touchscreen

8. Logo LED

INSTALLING THE BATTERY

Prior to using BioHarmonex®, the battery must be activated. To activate, pull out the safety foil on the battery cover.

Attention! Battery may need to be charged before use!

CHARGING THE BATTERY

The battery in the device is not fully charged, so for first time use, the device may operate for a shorter period than normal.

Charging the battery:

Connect the charging cable to the device.



Plug the charger into the socket. The colour of the Calivita® logo turns red, the battery indicator on the display changes to blue, and the charge level on the icon changes continuously. This indicates the charging process. BioHarmonex® can be used while charging. The battery is charged when the charge indicator animation is complete, next to the battery icon the charged percentage is shown and the Calivita® logo turns green.

When the battery is charged, first unplug the charger from the unit and then from the wall outlet.

If the device is not in use for several weeks, the battery may be drained so it may need to be charged before use.

ATTENTION:

If the color of the Calivita® logo changes to blue when charging, the unit indicates a charge failure. In this case, try charging the device with another official Bioharmonex® charger. If charging failure recurs, replace the charger.

TOUCHSCREEN

On the BioHarmonex® screen, the icons and buttons change according to the selection and the selected tasks. For more information, see the "Menu System" section.

Touch the display only with your fingertip or nail. Do not use any pointed tool.

ON / OFF

Press the On / Off button shortly for 1-2 seconds to turn the unit on. When it is on, press the button for 1 second to switch to standby mode.

To turn it off, press and hold the On / Off button for 3-4 seconds until the power-off message appears on the screen.

The device will turn off automatically when the battery charge status is too low for the device to operate. If this happens charge the device.



RESET

There may be cases when the device does not respond to the instructions on the touch screen. In such a case, you may need to restart your device.

To do this, press and hold the On / Off button for 10 to 12 seconds. The device will restart automatically.

OVERVIEW OF OPERATION

BioHarmonex® is easy and user friendly.

All functions can be accessed using the touch screen.

Navigation in all menus, submenus, and choices is accomplished with the buttons on the touchscreen. Activation of any menu choice, program, or function after selection is accomplished with tapping the button again. Use the "X" symbol in the top right corner to close application and step back. To return to the main menu directly, use the „☰” symbol in the upper left corner.

MODES

The device has the following modes:

ACTIVE MODE

This is the basic “On” mode, which displays the main window, and from which all menu choices, programs and functions are accessed and activated. In the middle part of the display the Calivita® logo can be seen, surrounded by the submenus. The backlight of the display is dimmed after 10 seconds and turns off automatically in 1 minute.

PROGRAM MODE

In this mode, a program is actively running. The display shows the name and the remaining time of the program, elapsed time, wave animation, sound and brightness icons, sliders, current date and time, and battery charge indicator. The backlight of the display is dimmed after 10 seconds and turns off automatically in 1 minute after starting the program. The running of the program is indicated by the pulsating Calivita® logo.



By briefly pressing the power button, the display returns to its active state. Once the program is finished, the device will automatically return to Active Mode and the backlight of the display will be active again for 1 minute. To terminate the program, press the "X" symbol in the top right corner.

STAND-BY MODE

If the device is in Active Mode and no button or scrolling function has been pressed for 1 minutes, the device will go into Stand-by Mode to conserve battery power. In this mode nothing can be seen on the display. Press on/off button to exit Stand-by Mode and return to Active Mode.

Aside from conserving battery power, the Stand-by Mode is also used to enable automatic running of programs at a pre-set time and day. The BioHarmonex® is not designed to turn itself on automatically, so the Stand-by Mode is essential for the automatic programming function to operate.

AUTO MODE

In order for the automatic running of programs to function, the device must have the Auto Mode set to 'ON'. If the Auto Mode is set to 'Off', programs can still be run but the running of any program set to run automatically at a pre-set time in the future will be suspended. For more information about Auto mode, see "Programming" section.

OFF MODE

To turn the device off, press and hold ON-OFF button for 3-4 seconds until the power-off message appears while the device is in Active, Stand-by or Program Mode.

ATTENTION:

In this mode the alarm function and running of any program automatically at a pre-set time is not possible.



THE MENU SYSTEM

MAIN MENU

When the device is turned on, the Main menu is displayed on the screen in "Active" mode. By touching the icons in the main menu, information appears in the center of the screen. You can touch the information text or touch the icon again to enter the submenu.

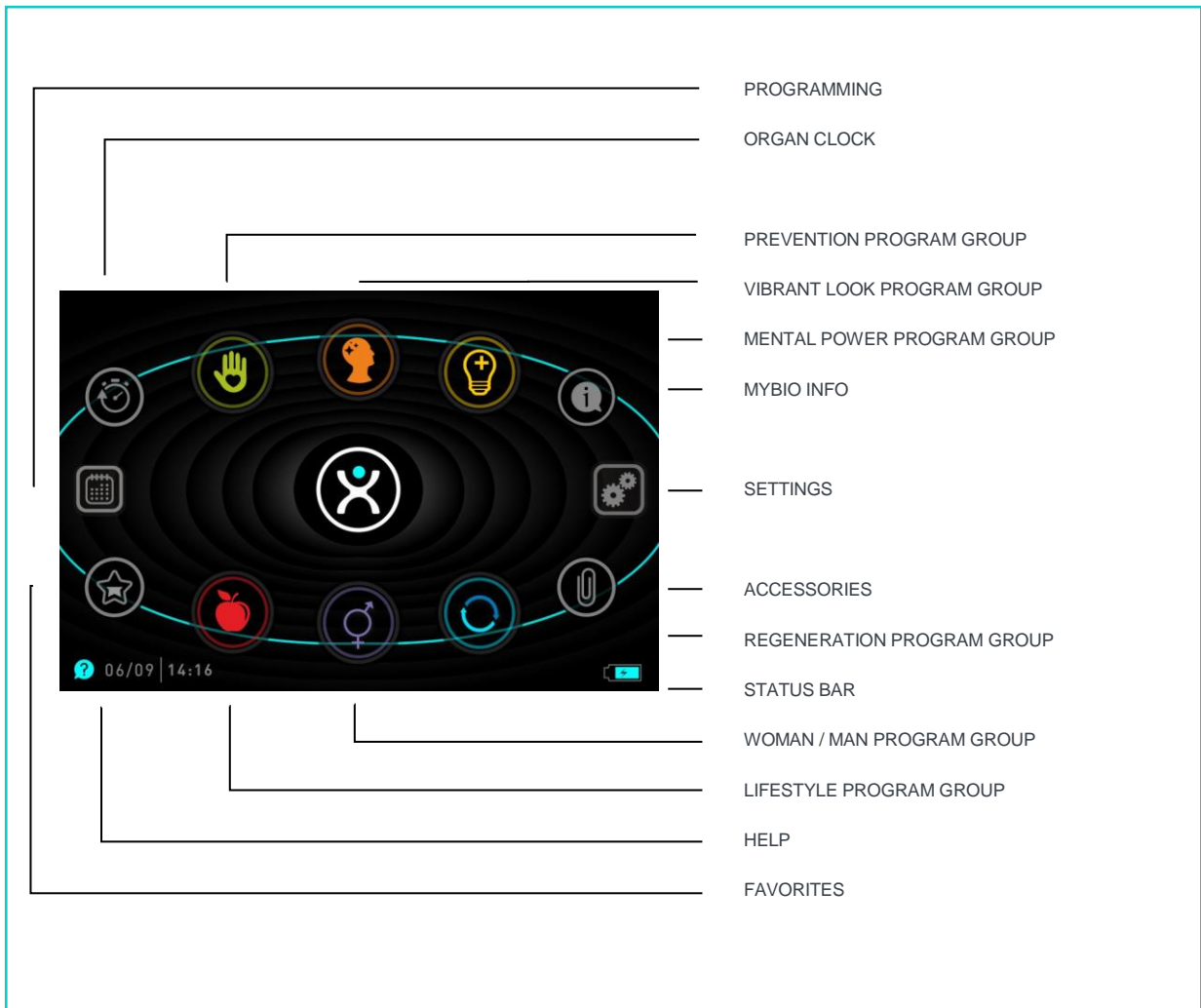



PROGRAM GROUP MENU

You can access program group menus by tapping the program group icons in the main menu and show the options available within the group. In these groups programs or other program groups can be found. Additional submenus are indicated by the small arrow next to the name in the list.

In each menu and submenu an "X" is displayed in the upper right corner of the screen which returns to the previous level, while the „≡" symbol in the upper left corner allows you to return to the main menu.

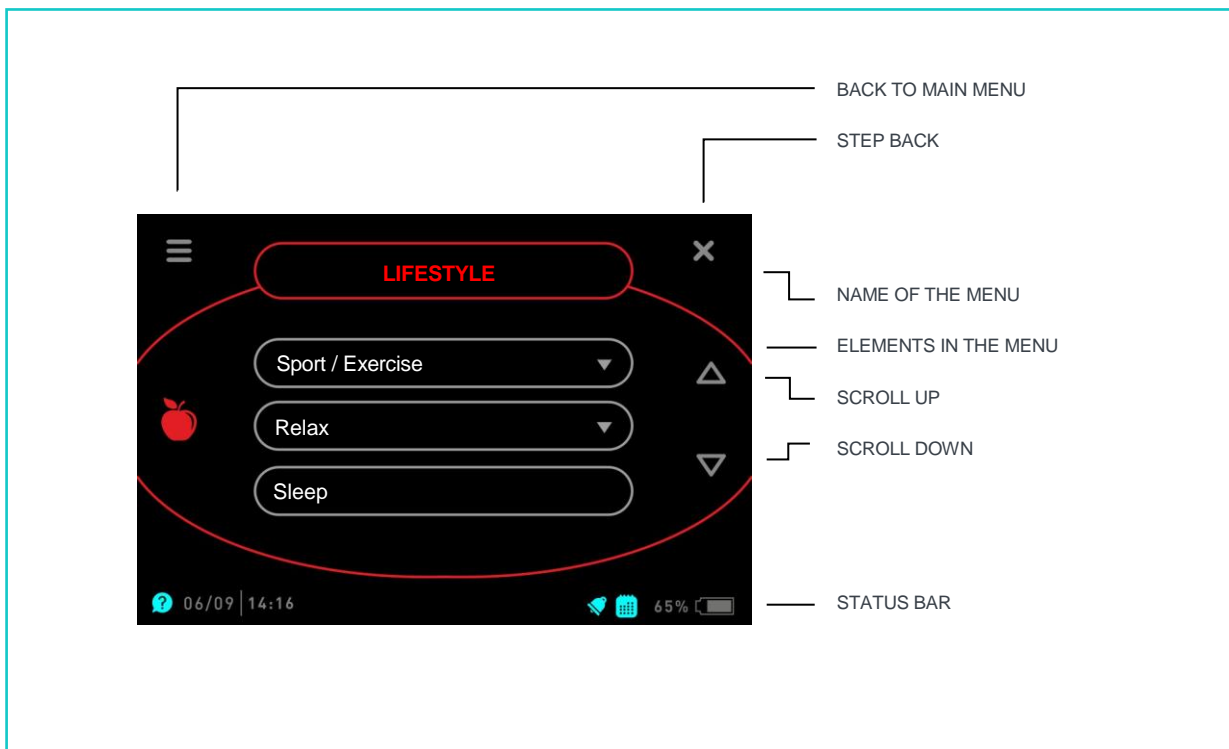



STARTING A PROGRAM

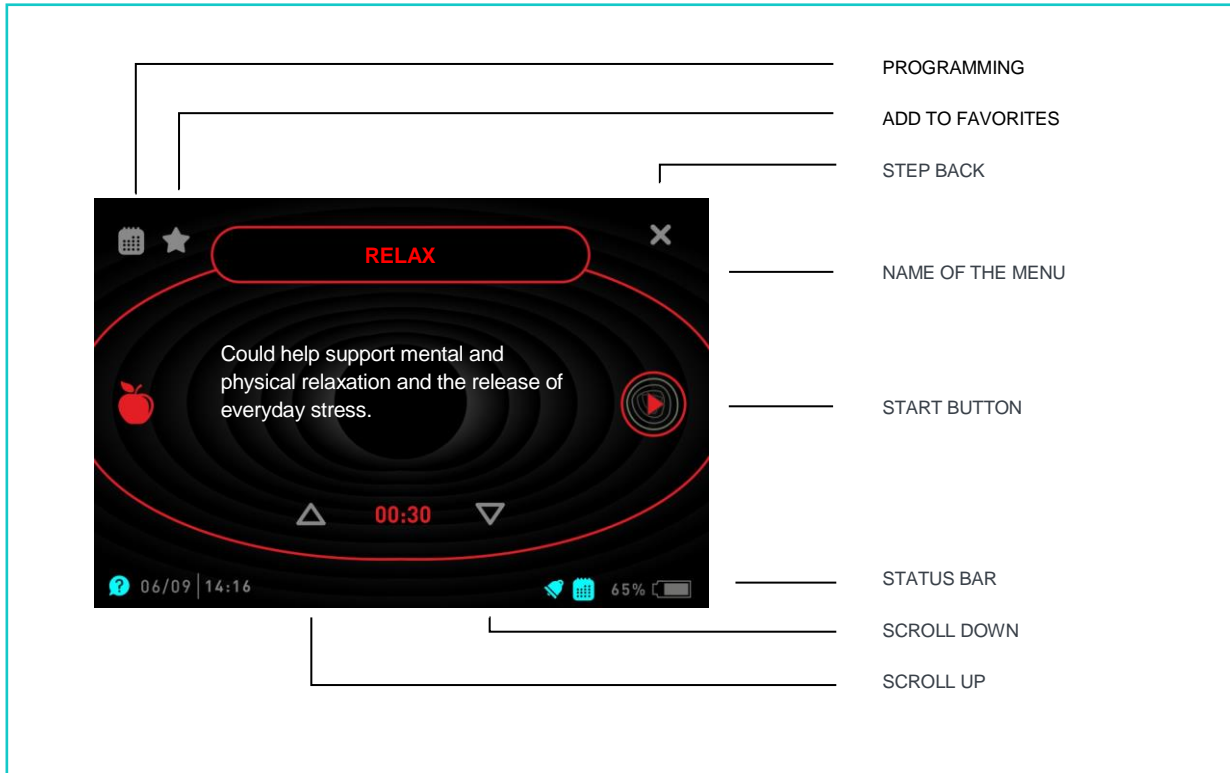

After touching the desired program, the program launch screen will appear on the display. At the top of the screen the name of the selected program, and below it a brief description can be seen. For more information about programs, please visit our website (www.bio-harmonex.com).



On the launch screen, you can start the program with the **start button**, or you can add it to your favorites or set it to run automatically at a pre-set time and day (see also section "PROGRAMMING").



Touch the **star** icon to add the program to your favorites. At this point, the "ADDED TO FAVORITES" prompt appears in the upper part of the display for a few seconds and the icon color changes to blue, indicating that the program is in the favorites group. Tap the icon again to delete the program from favorites. At this point, the "DELETED FROM FAVORITES" prompt will appear for a few seconds at the top of the display and the icon color will change to gray again.



Touch the **calendar** icon to go to the programming menu, allowing you to set the program for automatic running (see section "PROGRAMMING"). If you have already the program to run automatically, the icon color is blue.



PROGRAM RUN

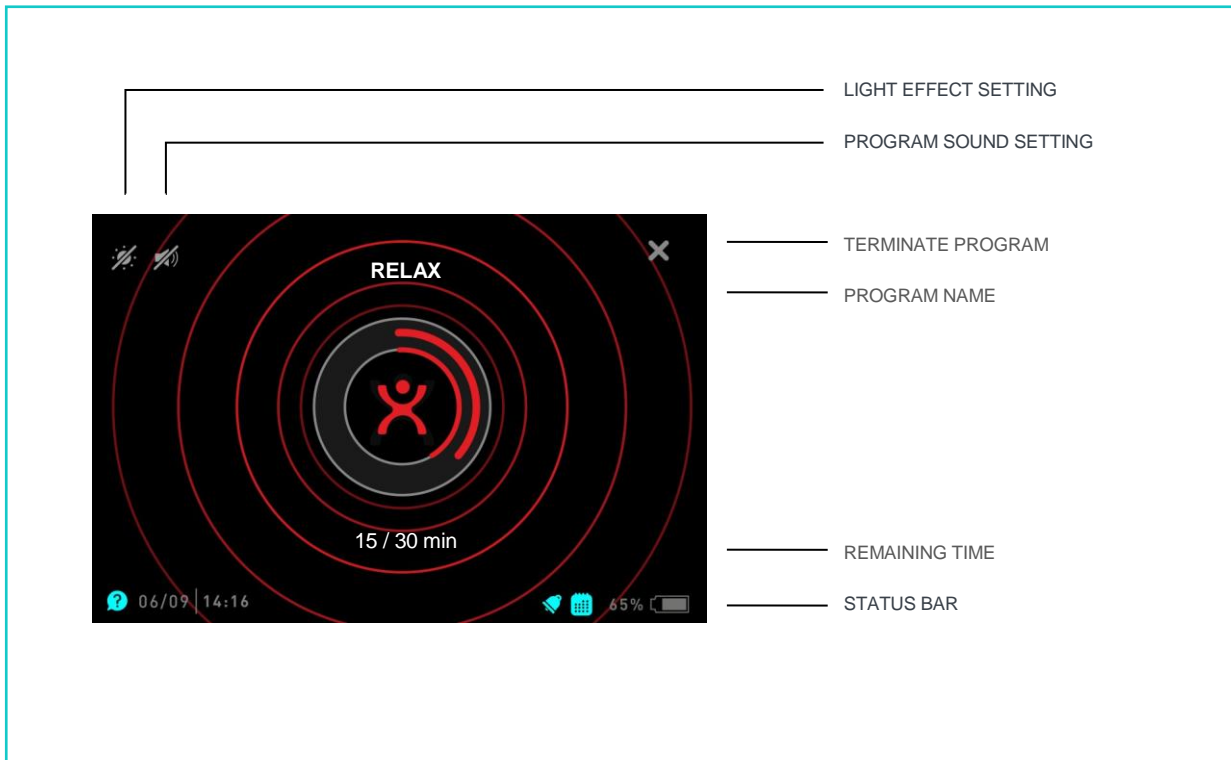

After the program is started, the display shows the name of the current program, the remaining time of the program, elapsed time, wave animation, the light and volume icon, the current date and time, and the battery charge indicator.

The backlight of the display will be dimmed in 10 seconds after the program is started and will automatically turn off after 1 minute. The running of the program is indicated by the pulsating Calivita® logo. At the end of the program, the unit switches to active mode and the "program finished" is displayed and then automatically switches to standby mode after 1 minute.



PROGRAM WITH SOUND



It is possible to supplement the electromagnetic field generated by the unit with sound waves. The default setting for the device is for the audio function to be disabled during the program run.

The acoustic signal can be switched on by tapping the loudspeaker icon while running the program.

The volume can be adjusted by dragging the slider.

To turn off the sound, tap the sound off icon on the bottom of the slider.



PROGRAM WITH LIGHT EFFECT



It is possible to supplement the programs with light effects. According to the default setting of the unit, the light effect function is off during the program run. The light effect can be turned on while the program is running by tapping the "light" icon.



The brightness can be adjusted by dragging the slider.

To turn off the light, touch the light off icon on the bottom of the slider.

TERMINATING A RUNNING PROGRAM

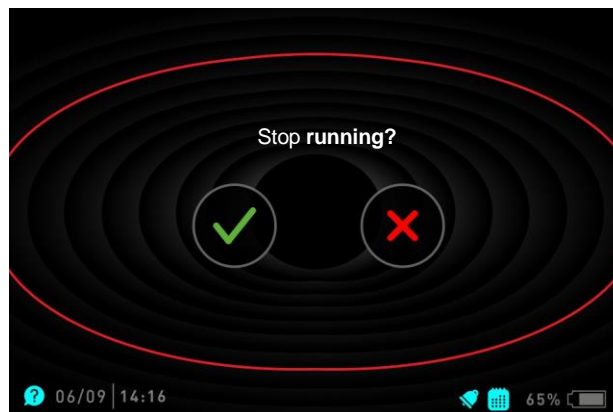

A running program can be terminated prior to completion by pressing the "X" symbol in the right upper corner of the display. In response to the popup question, you may decide to stop or resume the program.



SETTINGS MENU



Entering Settings menu allows the user to customize the device settings such as language, date and time. In this menu, you can also set the alarm, enter the activation code when you buy a new program, and choose computer data connection for updating the unit.



You can select these functions by touching the appropriate icon. Use the "X" symbol to step back.

ALARM

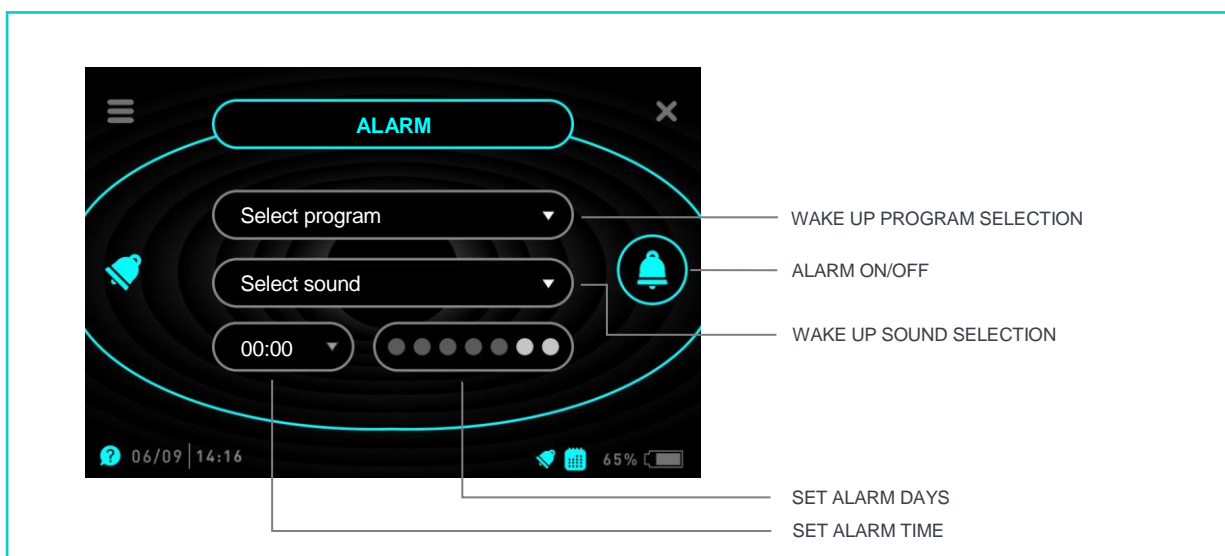

There are two programs in BioHarmonex® that can help you to wake up. Entering the alarm submenu, you can select the alarm tone, the alarm time and the alarm program.

ATTENTION: When you set an alarm program that may be in conflict with another autorun program (program collision), the alarm program will take precedence. This means an autorun program will not start, or will discontinue running once the alarm program starts. The autorun program will not automatically resume once the alarm program is finished. Autorun programs not in conflict with the alarm program will not be affected.



To turn the alarm on or off, press the wake-up icon on the right.



When the alarm is on, it is indicated by a small blue bell icon on the status bar.

The BioHarmonex's wake-up program may be unusual compared to your typical wake-up routine, so for the first few uses, we recommend using a traditional alarm in addition to the wake-up program.



IMPORTANT:

When setting the alarm, always check the time and battery level. If necessary, charge the battery.

ACTIVATING PROGRAMS

Each time you update your BioHarmonex®, all available programs will be downloaded to the unit. Those programs which haven't yet been purchased appear in gray. These programs cannot be used until they are purchased. After purchase, you need a special activation code, which you will receive upon purchase, to activate the program. These activation codes can be entered in the program activation menu.

To enter the code, tap "+" symbol on the display. Use the keyboard that appears to enter the code. Confirm the entry by touching the ✓ icon and confirm the code on the verification screen. With the activation code the program(s) that you have purchased will be available for use.

To return to the "SETTINGS" menu, press the "X" symbol in the top right corner of the display, while the „≡” symbol in the upper left corner allows you to return to the main menu.

PROGRAM ACTIVATION CODES

ACTIVATION CODE, DELETE BACK WITH „<” SIGN

CONFIRM ACTIVATION CODE

ENTER CODE USING KEYBOARD



USB DATA TRANSFER

The fourth generation BioHarmonex® allows for continuous improvements and updating of the software through the internet. Any software bugs can be repaired by updating, and new features and programs can be added to the device.

After installing the BioHarmonex's client program, the program will note the current software information on your device and, if any updates are available, a message appears in the lower right corner of your computer.

To establish a data connection, you must do the following:

1. Download and install the client software on your computer from www.bio-harmonex.com.
2. Connect the BioHarmonex® to your computer using the micro USB-USB cable included in the package.
3. Enter the "USB DATA TRANSFER" submenu in the "SETTINGS" menu of the BioHarmonex®.
4. Wait until the previously installed client program on your computer recognizes and reads your BioHarmonex® data.
5. If there is an update available, start it by selecting the YES option.
6. Updates will be automatically downloaded and installed on your device.
7. After downloading the update files, the device will disconnect from the computer and automatically start the update. Please do not switch off the BioHarmonex®, wait until the software update is finished. You can track the installation process on your device's display.
8. The device restarts when the update is complete.



NOTE:

After you have installed the client program to your computer, select the „auto-start with the system” option in program settings to get notification of any updates automatically.



LANGUAGE

The default language setting for the BioHarmonex® is English. This can be changed to any of the languages shown in the language menu of the device. The languages are in alphabetical order and the current language being used is always on the top. Use the arrows on the right to move in the list of languages. After touching the desired language, a confirmation of language change is displayed.

Tap the  icon to change the language of the device while touching the  icon will return your device to the list of languages.



DATE/TIME

Setting the date and time is needed for BioHarmonex® to automatically run programs at a pre-set time (see PROGRAMMING section), to show the Organ clock programs at the right time, and to set the alarm correctly.





SET TIME

Entering the "Date / Time" submenu, first select the hour from the hour / minute symbols at the bottom of the screen by touching the left bottom frame. Set the hour on the clock symbol in the middle. For adjustment, swipe your finger on the clock symbol or use the right arrow keys to scroll.

After you have set the hour, select the minute by touching the right bottom frame. Set the minute on the clock symbol in the middle. For adjustment, swipe your finger on the clock symbol or use the right arrow keys to scroll.

- ✓ Touch the check mark on the left side of the display to finalize the time setting.



The device returns to the Settings submenu. If you want to go back without changing the time, use the „X” symbol in the right upper corner.

SET DATE





Entering the "Date / Time" submenu, first select the year from the year / month / day symbols at the top of the screen by touching the left upper frame. Set the year on the clock symbol in the middle. For adjustment, swipe your finger on the clock symbol in the middle or use the right arrow keys to scroll.

After you have set the year, select month by touching frame in the middle on the top. For adjustment, swipe your finger on the clock symbol in the middle or use the right arrow keys to scroll.

After you have set the month, select minute by touching right upper frame. For adjustment, swipe your finger on the clock symbol in the middle or use the right arrow keys to scroll.

The name of the day changes automatically in the lower part of the display.

 Touch the check mark on the left side of the display to finalize the setting.

The device returns to the Settings submenu. If you want to go back without changing the time, use the „X” symbol in the right upper corner.

ABOUT

In this submenu, the serial number and the current software version of the device is displayed.

PROGRAMMING (MYBIO PROGRAMS)



Any programs in BioHarmonex® can be set to start automatically at a pre-set time and day. As well the device will allow multiple programming, where several different programs can be independently set to run at a certain day or time although only one program can run in a specific time slot.



Entering the submenu shows a list of programs in the middle of the display that have been set for autorun. If no program has been set, you can add a new program with the "+" icon in the middle of the display.

The maximum number of programs that can be pre-set to run is 30. The user can add, delete or change the day and starting time of any program in the automatic programming function. The settings for any pre-set running of programs will remain as set unless the user changes it.

ATTENTION! Automatic program running is possible only when the device is in Stand-by or Active Mode. Automatic running is not possible when the BioHarmonex® is switched off. Replacing of batteries does not affect or delete the automatic programming settings.

NEW PROGRAM

To set a new program to run automatically, follow these steps:

In the "PROGRAMMING" menu, touch the "+" icon.

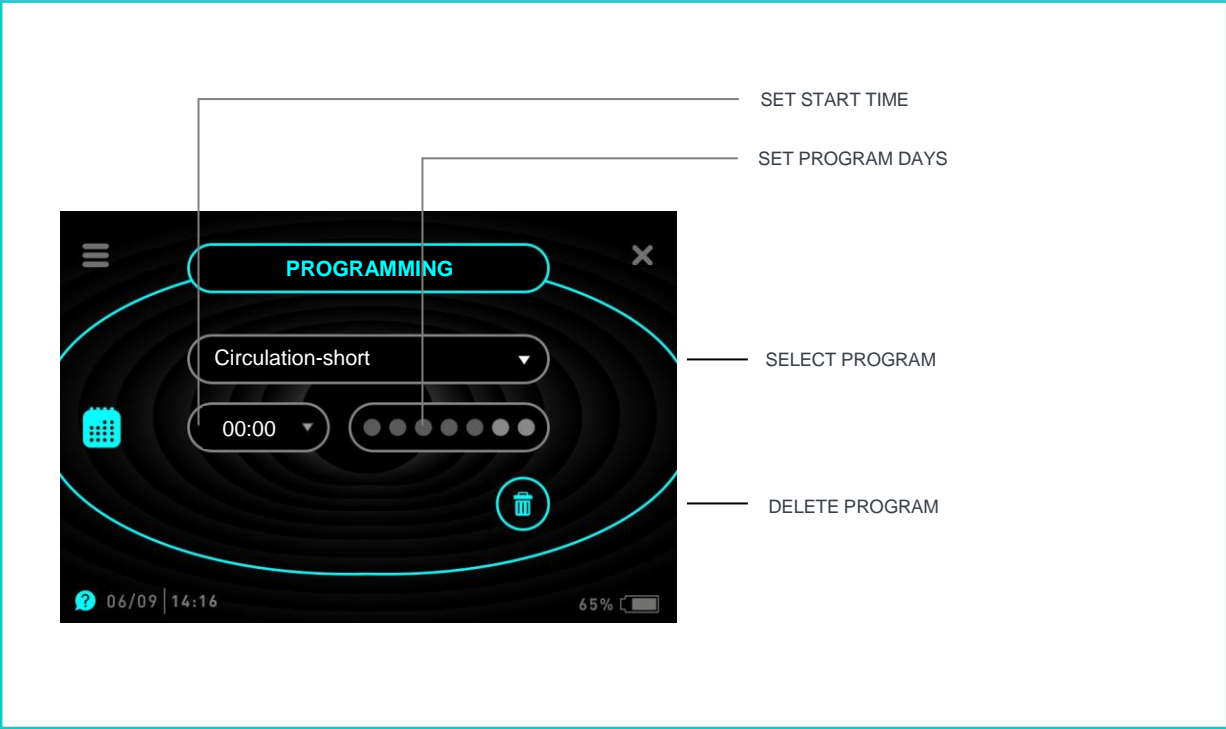

From the "Program selection" list on the display, select the desired program. To do this, touch the subtitle and then search the program you want to run automatically from the main program groups that appear in the list. The grouping of programs is the same here as the program groups in the Main Menu of the device. After you found the program, select it by tapping the icon (✓) on the right.



After the program is selected, set the start time according to the "Time Setting" section. To do this, touch the button (00:00) to the left under the selected program name.

After setting the start time, select which days of the week you want the program to run automatically. Select the program days by touching the small circles under the name of the program . Tap the days you want to autorun the program. The colors of the selected days change to blue. Finish the setting by tapping the check mark on the left.

ATTENTION: If you do not select any day, the program will not start!

The display shows a summary of the program name, start time, and selected days, indicated by small blue circles.



To save the program, tap the icon on the left.



If you do not want to save your settings, you can delete them by tapping the icon.

ATTENTION! All settings indicated above must be made for automatic running of a program. If the autorun settings are incomplete, the program will not automatically run as planned. If, during set up, you decide not to autorun the program, press the "X" button to cancel the process.

The BioHarmonex® is not designed to run two or more programs simultaneously. If you are setting a program to run at the same day and time as another program that has been previously entered into the automatic programming memory, the display will show the following message: 'PROGRAM COLLOSION'. After this message has been displayed, the device reverts to program summary allowing you to change the starting time of the additional program you are trying to autorun.

The BioHarmonex® automatic programming memory can hold 30 different automatic settings. If the memory capacity is full, a 'MEMORY FULL' message will appear on the display for 2 seconds, after which the display will automatically revert to the "AUTORUN" menu. In this case, additional new programs cannot be entered into the automatic programming, unless some of the programs previously entered into the automatic programming memory are deleted.



PROGRAM MODIFY / DELETE

It is possible to modify or delete all parameters of a previously set program. To do this proceed as follows:

Entering the "Programming" menu, you will see a list of programs you have set to run automatically. Touch the program you want to edit or delete.

The unit displays the program data according to the "New program" section.

In case of any modification, change program parameters as described in "New Program" section.

Tap the OK icon to save the changes.

When deleting the program, touch the dustbin icon on the right and confirm the deletion at the popup warning. By selecting "no" the unit reverts to program summary.

To exit this menu, touch the „X” symbol in the upper right corner.

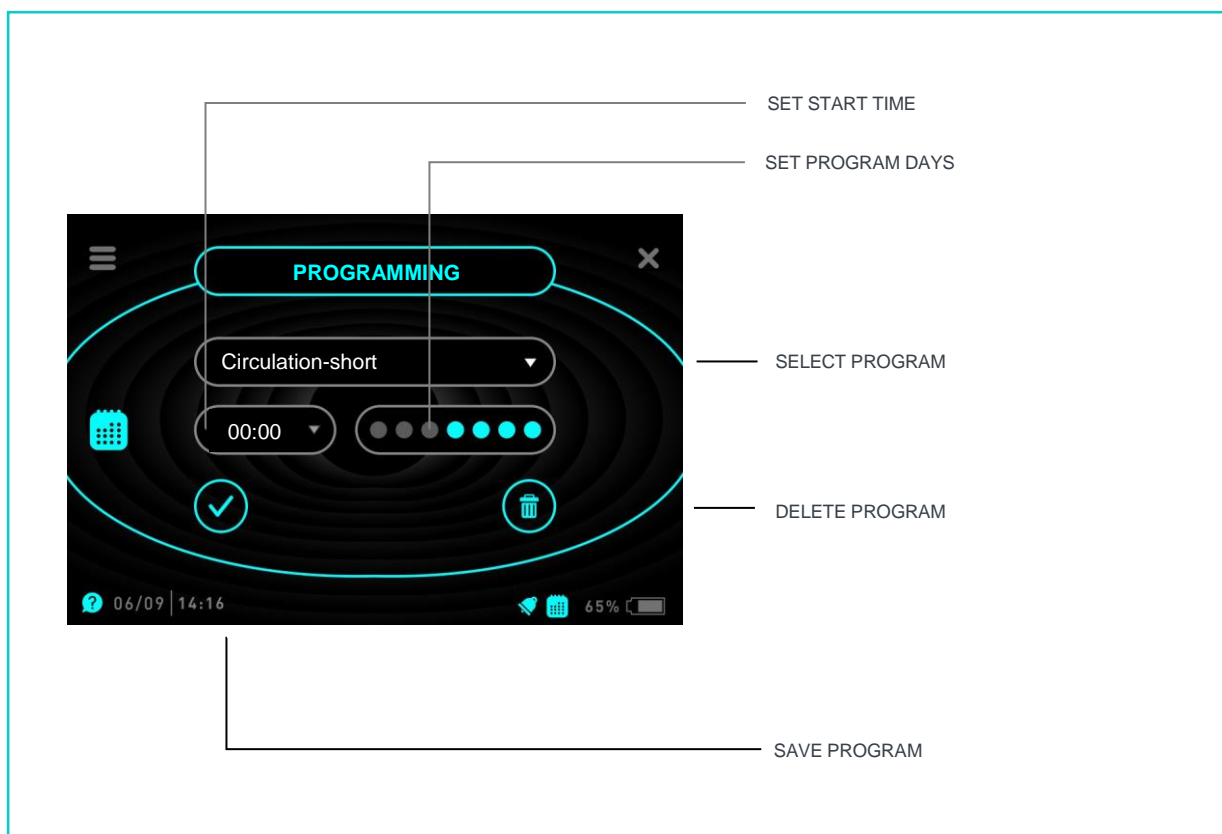



AUTO MODE

The “AUTO MODE” is used for the temporary suspension or re-activation of the autorun programs. The default setting for the BioHarmonex® allows the automatic programming and running of the programs. If you wish to temporarily suspend automatic running of any program, then re-activate it at a later date, follow these steps:

In the PROGRAMMING menu, tap the auto mode off icon on the bottom of the screen.

After activation a larger image of the auto mode off icon appears at the middle of the screen indicating that the automatic program running function has been temporarily suspended.

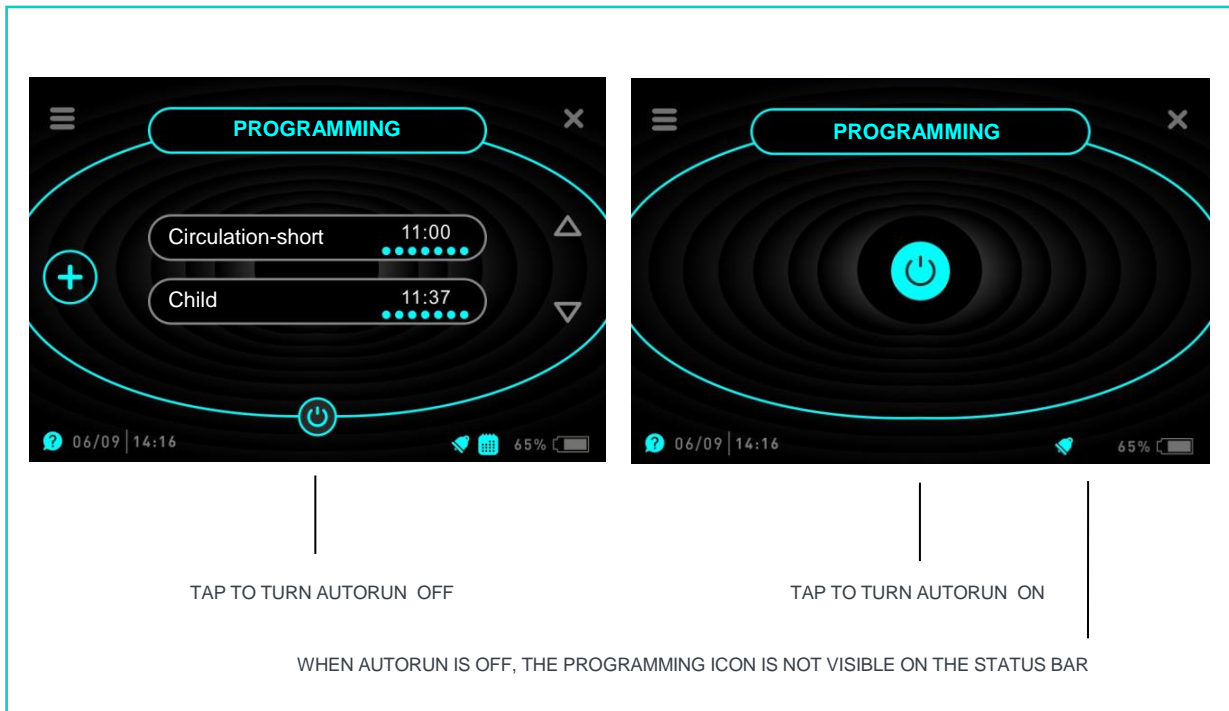

Touching the Auto Mode Off icon will automatically re-enable the automatic program running and the list of programs that have already been set appears in the middle of the display.

If any program has been set to run automatically, and the auto mode is turned on, a small blue calendar icon will indicate the enabled autorun program on the status bar.



When the autorun function has been de-activated all programs previously programmed into the autorun memory will remain in the memory, but they will not run at the programmed time. Once the autorun function has been re-activated, all the programs previously programmed into the memory will commence running at the appointed time and day. De-activating the autorun program function only suspends automatic running but does not change any of the programs or parameters in the autorun memory.



ORGAN CLOCK INFO

According to traditional Chinese medicine, the status of our body is constantly changing, and optimum functioning of various organs happens only at certain times of the day. Based on this system, the Bioharmonex® Organ Clock helps you to see during what times of day it is favourable to heal, relax or work certain organs. The function specifies 12 organs, and 12 times of day. In this menu, you can get information about the activity of the 12 organs, and this information helps you to select and create an optimal program run for the day.





Clicking on the Organ clock icon will display a clock symbol on the screen. In the center of this clock, the active organ image is displayed according to the time period. The organ's activity interval is indicated in blue in the clock symbol. You can move forward or backward in this list using the arrows on the left and right of the clock, or touch directly the selected time period on the outside of the clock symbol to jump to the desired time.

By clicking on the question mark on the bottom of the screen, the organ clock information of the selected organ is displayed. To return to the Organ clock, touch the "X" symbol in the upper right corner of the display, while the „☰” symbol in the upper left corner allows you to return to the main menu.

STARTING A PROGRAM IN THE ORGAN CLOCK

In the Organ clock menu, by touching the organ in the center of the clock symbol, a list of program(s) belonging to the given organ appears on the display. If there is no program available for the given organ in the device, the "There is no available program for this organ yet" message is displayed.

Tap the program name in the list to jump to the program start, where you can start (), add to favorites () or set it to run automatically () at a pre-set time and day. When you set the program to run automatically from this menu, the BioHarmonex® will offer the cycle time of the organ for the start time of the program as default.



Touch the „X” symbol to step back to the list of programs belonging to the organ, or touch the „☰” symbol in the upper left corner to return to the main menu.



After you have set up an auto-run program for the organ, the body's image will be inverted (blue background) in the center of the clock symbol.

FAVORITES



The "Favorites" menu item shows the favorite programs that you have added to the list in alphabetical order. You can use the right arrows to move in the list. By tapping any program, the device will jump to the program start menu of the given program.

To edit the list (remove a program), tap the program, then tap the blue star (★) icon on the launch screen that appears. At this point, the "DELETED FROM FAVORITES" prompt will appear for a few seconds at the top of the display and the icon color will change to gray. If you choose not to remove the program from the list, tap the (★) icon again, and the "ADDED TO FAVORITES" prompt appears in the upper part of the display for a few seconds and the icon color changes to blue again, indicating that the program has been returned to the favorites group.

To return to the favorites list, touch the „X” symbol in the upper right corner of the display.



MYBIO INFO

The Mybio info menu allows you to view the device's daily routine.



The list on the display shows chronological order of data from the Organ clock, programming and alarm menus.

The current information is displayed in blue color, the following ones in white, while the past events are shown in gray.

You can use the right arrows to move in the list.

ACCESSORIES



To establish a data connection required to operate other accessories of BioHarmonex®.

This function will be available only later.

BUILT-IN HELP

BioHarmonex® has built-in help function for easier usage.



Touch the blue question mark icon in the bottom left corner to display the help for that screen.

In the help screen that appears, you can use the arrows on the top to scroll forward or backward. If there is additional text for that screen, you can view it using the arrows on the bottom left and right of the display.

To exit and return to the menu, touch the „X” symbol.

LIMITED WARRANTY

The manufacturer warrants that this product is free of defects of material, design and workmanship for the period of sixty (60) months from the original purchase date as indicated on the sales receipt. Retain your original sales receipt as it may be required for you to qualify for warranty servicing or replacement. The warranty does not include the battery!

If, during the period of warranty, this product proves defective under normal use and service, you should return the product to the retailer from whom it was originally purchased. The liability of the manufacturer is limited to the cost of repair and/or replacement of the unit under warranty.

Return of the product for warranty servicing should be to the original vendor.



WARRANTY CONDITIONS

- The warranty is only valid upon presentation of the proof of purchase consisting of original invoice or sales slip confirmation, indicating the date of purchase, dealers name, model and serial number.
- The manufacturer reserves the right to refuse warranty service if this information has been removed or changed after the original purchase of the product from the dealer.
- The manufacturer's obligations are for repair of the defective part and at its discretion, replacement of the product (service exchange unit).
- Warranty repairs must be carried out by the manufacturer. The warranty does not apply for repairs carried out by a non-authorized persons, and the warranty will not apply for any repairs or damage caused by such unauthorized repairs.
- Repair or replacement under the terms of this warranty does not give you an extension to, or a new start to the period of warranty. Repair or direct replacement under the terms of this warranty may be fulfilled with a functionally equivalent service exchange unit.
- The warranty is not applicable in cases other than defects in material, design and workmanship. The warranty does not cover the following:
 - Repair and replacement of parts due to normal wear and tear.
 - Abuse or misuse, including but not limited to the failure to use this device for its normal purposes, or in accordance with the instructions for usage and maintenance.
 - The device has been used in conjunction with accessories not approved by the manufacturer for use with this device.
 - Failure of the product arising from incorrect installation, or use not consistent with expressed technical or safety standards, or failure to comply with product manual instructions.
 - Accidents, Acts of God or any cause beyond the control of the manufacturer caused by, but not limited to, lightning, water, fire, public disturbances.



- Unauthorised modifications carried out for the product to comply with local or national technical standards in countries for which the device was not originally designed.
- Damage of the battery caused by overcharging or failure to use in accordance with the specific instructions of care outlined in the product manual.
- Repairs performed by non-authorized service centers, and opening of the device by a non-authorized person.
- The model and serial number on the product has been altered, removed or made illegible.
- The battery has been charged by other than the original, approved battery chargers.
- Exposure to moisture, dampness or extreme thermal or environmental conditions or rapid changes in these conditions.
- Spillage of food or liquid.
- This warranty does not affect the consumer's statutory rights, nor the consumer's rights from the dealer from their purchase/sales agreement.
- This warranty will be the purchasers sole and exclusive remedy and neither the manufacturer nor its subsidiaries or distributors shall be liable for any incidental or consequential damages for breach of any express or implied warranty of this device.
- Repaired or replaced products may include new/or refurbished components and equipment.



TROUBLESHOOTING

PROBLEM

SOLUTION

Unit switches off

Battery is low, connect the charger.

Screen is black

The device may be switched to standby mode.

Press the on/off button.

If the screen remains black, try to reset the device by pressing and holding the on/off button for 12 seconds. If nothing happens, the battery may be low. Connect the charger. If it still doesn't work, contact your distributor!

The unit does not charge

Check the charger cable. If damaged, replace cable or charger.

If it still doesn't charge, contact your distributor!

Calivita® logo turns to blue when charging

The BioHarmonex® indicates a charging problem. Try charging the device with another network charger. If the problem persists, replace the charger.

Touchscreen problem

Try to restart the device. If it still doesn't work, contact your distributor!

Unit freezes

Try to reset the device by pressing and holding the on/off button for 12 seconds. If nothing happens, contact your distributor!

Battery drains too fast

Replace the battery. Please contact your distributor!



BioHarmonex[®]

WWW.BIO-HARMONEX.COM

